

(No Model.)

3 Sheets—Sheet 1.

C. G. FREEMAN.

GRINDING MILL.

No. 357,767.

Patented Feb. 15, 1887.

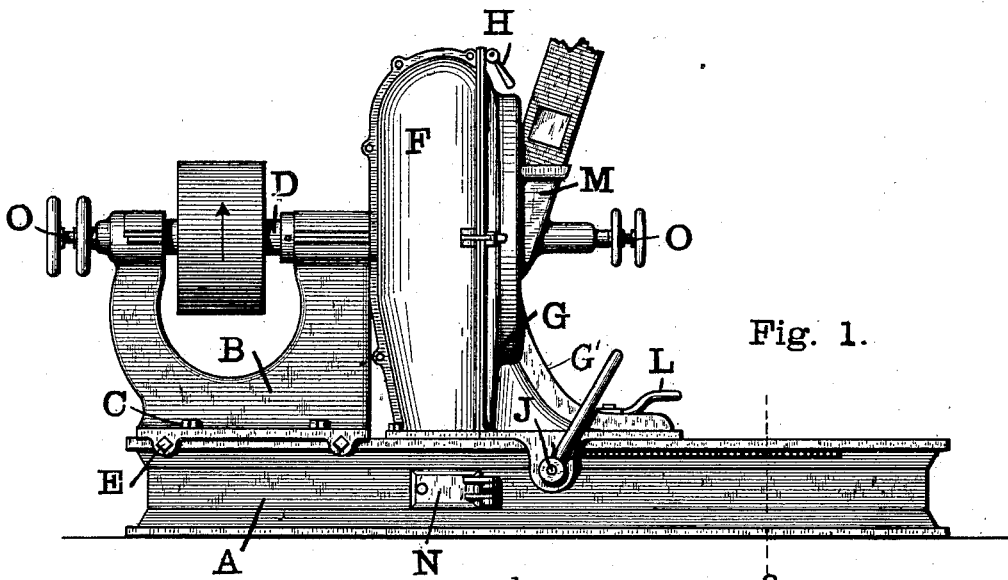

Fig. 1.

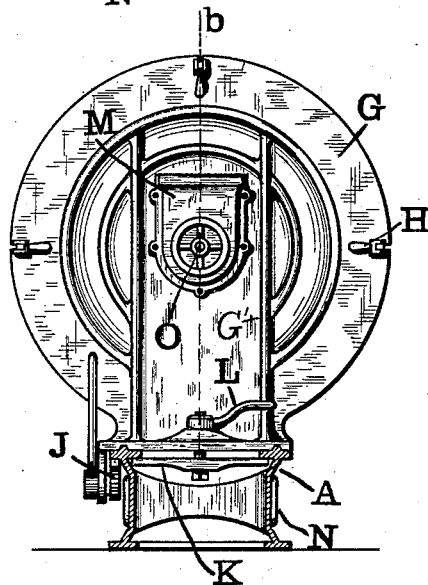

Fig. 2.

WITNESSES:
W. J. Barber
W. A. Leonard

Claudius G. Freeman
 INVENTOR
 by *James W. See*

ATTORNEY

C. G. FREEMAN.
GRINDING MILL.

No. 357,767.

Patented Feb. 15, 1887.

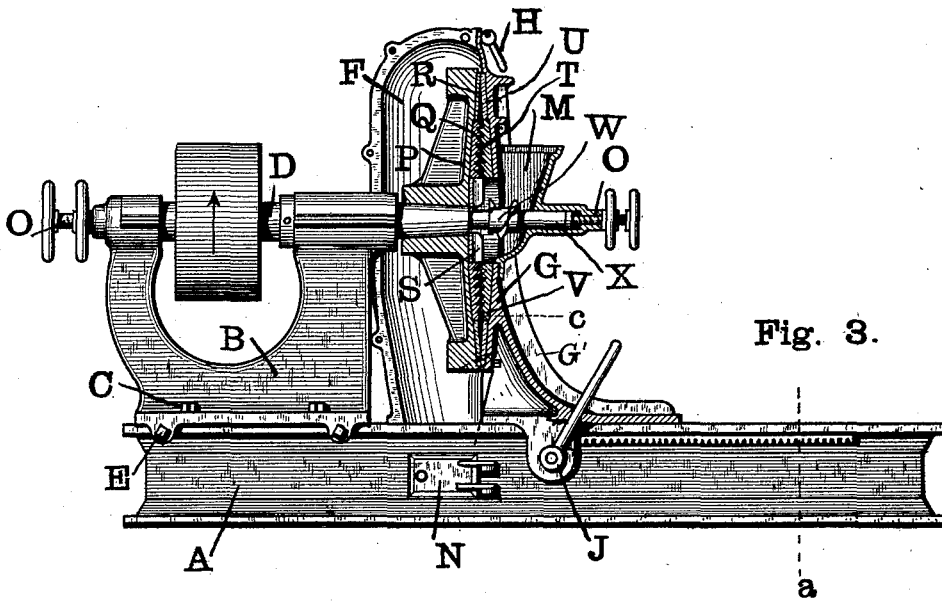

Fig. 3.

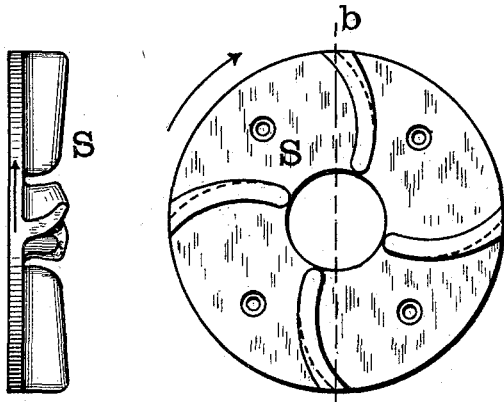

Fig. 4.

Fig. 5.

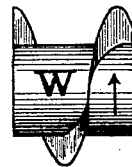

Fig. 6.

Claudio G. Freeman

INVENTOR

WITNESSES:
W. J. Barner
W. S. Bernard

James W. See

ATTORNEY

C. G. FREEMAN.
GRINDING MILL.

No. 357,767.

Patented Feb. 15, 1887.

Fig. 7.

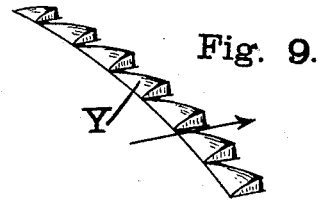
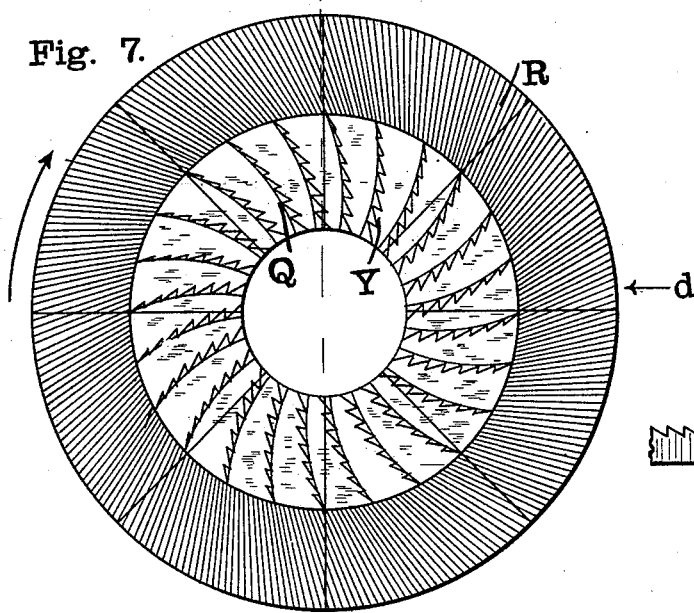

Fig. 9.

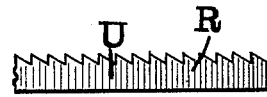

Fig. 10.

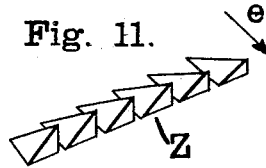
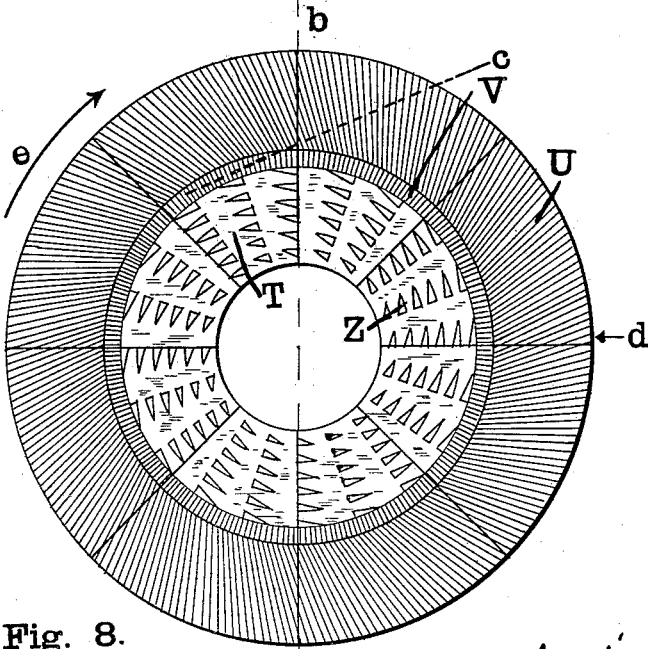

Fig. 11.



Fig. 12.

Fig. 8.

WITNESSES:

W. G. Garver.
W. S. Bernard

Claudio G. Freeman

INVENTOR

by James W. See

ATTORNEY

UNITED STATES PATENT OFFICE.

CLAUDIUS G. FREEMAN, OF CINCINNATI, ASSIGNOR OF ONE-HALF TO
ORVILLE SIMPSON, OF COLLEGE HILL, OHIO.

GRINDING-MILL.

SPECIFICATION forming part of Letters Patent No. 357,767, dated February 15, 1887.

Application filed May 15, 1886. Serial No. 202,322. (No model.)

To all whom it may concern:

Be it known that I, CLAUDIUS G. FREEMAN, of Cincinnati, Hamilton county, Ohio, have invented certain new and useful Improvements in Grinding-Mills, of which the following is a specification.

This invention pertains to improvements in mills intended, primarily, for grinding cotton-seed, but obviously adapted for the grinding of other materials.

The improvements will be readily understood from the following description and claims, taken in connection with the accompanying drawings, in which—

Figure 1 is a side elevation of a grinding-mill embodying my improvements; Fig. 2, an elevation of the right-hand face of the same, the bed appearing as in section upon line *a*; Fig. 3, a side elevation similar to Fig. 1, but showing various parts in vertical section upon line *b*; Fig. 4, a side elevation of the feeder-disk; Fig. 5, a face view of the feeder-disk; Fig. 6, a side elevation of the feeder-worm; Fig. 7, a face view of the running grinder; Fig. 8, a face view of the standing grinder; Fig. 9, a perspective view of one of the rows of teeth of the running grinder; Fig. 10, a view at the edge of either the running grinder or standing grinder, viewed in the direction indicated by arrow *d*; Fig. 11, a perspective view of a row of teeth of the standing grinder; and Fig. 12, a section of the inner marginal teeth, *V*, upon line *c*.

This mill employs two grinding-disks, arranged with their acting faces in juxtaposition. In the preferable form illustrated one of the disks or grinders is a running grinder, and the other is a standing grinder.

In the drawings, arrows have been placed upon some of the figures, indicating the direction of rotation of the parts; but attention should be called particularly to the arrows *e* of Figs. 8 and 11. The parts to which these arrows are applied are not running parts—that is, they stand still during the grinding operation; but it has been thought that the operation will be much better understood from the drawings if these arrows were added to indicate a direction of action rather than a direction of motion. Therefore it should be understood that the arrows *e* in Figs. 8 and

11 indicate the direction of grinding action of standing or stationary parts, instead of the direction of motion of running parts.

In the drawings, A indicates a horizontal bed similar to the bed of an ordinary metal-turning lathe; B, a head-stock, similar to the head-stock of a lathe, bolted to the bed and carrying a pair of journal-boxes; C, bolts by which the head-stock is secured to the bed, these bolts passing through large or slotted holes, so as to permit a certain amount of side adjustment of the head-stock upon the bed if the bolts are loosened; D, a spindle journaled in the head-stock and provided with a belt-pulley for its rotation; E, set-screws tapped horizontally through downwardly-projecting side lugs on the base of the head-stock and engaging against the sides of the bed, these set-screws serving in properly adjusting the head-stock sidewise; F, a disk-like case disposed axially with reference to the spindle and closely against the front of the head-stock, and having its face and its base open, the case being formed in two halves jointed upon a vertical diametrical line, and having its base secured, as by bolts, to the top of the bed; G, a disk-like cover for the front of the case, this cover being formed, provided, or connected with a knee which bears and is fitted to reciprocate upon the top of the bed, and serves as the supporting provision for the cover and for the standing grinder within the cover; G', a knee, bearing with its base upon the bed of the mill and reaching upward into connection with the cover, this knee serving as a rigid support for the standing grinder, which is secured to the inner face of the cover, and also for the cover; H, links pivoted at the periphery of the case and adapted to swing into engagement with notches in the cover, the links being provided with handled cams by means of which, when the cover is placed against the case, it may be drawn up firmly to the case, so as to make a tight joint therewith; J, a rack-and-pinion mechanism by which the cover, when unlocked from the case, may be reciprocated upon the bed, the construction and operation being similar to that of the mechanism by which a lathe-carriage is moved, the pinion being rotated, preferably, by means of a lever fitted with a double ratchet, the well-known

Lowell wrench of the market being the device I usually employ; K, a clamp-bar disposed across the bed below inner flanges at the top thereof, this clamp-bar being arranged below the knee of the cover and connected thereto by a bolt, the clamp-bar serving to secure the cover firmly to the bed, similar to the manner in which the tail-stock of a lathe is secured to the bed, the clamp-bar in the present case, however, being made of only sufficient strength to perform its normal duty and to break when subjected to abnormal strains; L, a clamp-bolt and nut by which the clamp-bar is drawn to its work; M, an inlet-nozzle adapted for the reception of the supply-spout, and leading axially to the interior of the cover and case, this nozzle forming the point at which the cotton-seed or other material to be ground is fed to the machine; N, openings and doors in the two sides of the bed at the base of the case, these openings serving to permit access to the interior of the bed for the purpose of connecting outlet spouts or conveyers or the like to the base of the case for the conveyance away of the ground material; O, step-screws engaging the opposite ends of the spindle and forming step-bearings therefor, and serving to adjust and maintain it in correct endwise position, one of these screws being supported by the outer bearing of the head-stock and the other by a piece projecting outwardly from the cover; P, a concave disk rigidly secured to the spindle, within the case, and having an exceedingly heavy rim to serve as a fly-wheel, this disk, with its facial attachments, forming the running grinder; Q, a concentric series of segments firmly secured against the face of this running disk and provided with teeth formed, preferably, of phosphor-bronze, which is the preferable material to be employed in forming all of the active grinding parts; R, a concentric series of segments secured to the face of the running disk outside of the series of toothed segments, these outer segments being formed with tangentially-disposed flutes presenting vertical faces and sloping backward, as shown in Fig. 10; S, a feeder-disk secured at the center of the running disk around the spindle, and provided with facial blades reaching in a curved line from eye to periphery and having their edges thrown in advance of their heels, as clearly shown in Figs. 4 and 5, the feeder-disk being of a size corresponding with the size of the central inlet-opening through the cover; T, a concentric series of toothed segments secured to the inner face of the cover, the cover forming the standing grinder and having a concave face similar to the running grinder; U, a concentric series of fluted segments similar to the segments R, secured to the cover around outside the series of toothed segments, the teeth of the outer segments being the same as the teeth of the segments R, as shown in Fig. 10; V, an annular circle of short radially-arranged flutes disposed upon the cover between the toothed segments T and the fluted segments

U, this intermediate fluted circle being formed upon the facial peripheries of the toothed segments T, the flutes of this intermediate circle having both of their faces sloped, as shown in Fig. 12, the inner diameter of the circle V being less than the outer diameter of the toothed segments Q; W, a feed-worm secured upon the spindle at the foot of the inlet-nozzle and just in front of the feeder-disk, this feed-worm having a direction of helix adapted to draw the material from the nozzle inward toward the feeder-disk; X, an end portion of the spindle journaled in the central outwardly-projecting boss of the cover and engaged by the step-screw of the cover; Y, the teeth of the segments Q of the running grinder, these teeth being disposed in radial but curved lines, presenting their convexity forward in the direction of motion, the teeth presenting cutting-edges in the direction of motion and having their tops sloped so that the teeth present a series of elevated frontal points, as shown in Fig. 9; and Z, the teeth of the segments T of the standing grinder, these teeth being arranged in radial lines and presenting flat faces in the direction of their action, and having their tops sloped so as to form frontal points, as clearly shown in Fig. 11.

Material being admitted at the inlet-nozzle, the feed-worm carries it toward the feeder-disk. The feeder-disk throws it radially between the toothed grinders by centrifugal action, and the hook-like advance of the edges of the blades of the feeder-disk prevents the recession of the material backward from its face. The material is coarsely cut or cracked by the action of the knife-like teeth of the running-grinder passing between the flat-faced teeth of the standing grinder. The material moving outwardly by centrifugal action becomes subjected to the action of the teeth at points where the teeth engage more closely by reason of the concavity of the plates. The material reaches the circle of flutes V, and is held by them while acted upon by the outer teeth of the segments Q. The material is then acted upon by the circles of flutes R, and subjected to substantially a grinding action. The material then leaves the grinders and falls through the bottom of the case, whence it is conveyed away as desired.

The relation of the face of the running grinder to the face of the standing grinder may be delicately regulated by means of the two step-screws O, which serve in adjusting the spindle endwise and maintaining it in any desired position. These step-screws are to be provided, of course, with thrust-bearing faces of suitable material—as, for instance, phosphor-bronze or hardened steel.

The head-stock may be adjusted by means of the set-screws E to bring the spindle in accurate line with the axis of the cover.

The bearing X of the spindle in the cover serves to index the correct annular relation of the head-stock to the cover and to give increased steadiness to the running of the spin-

dle. The cover is readily withdrawn entirely from engagement with the spindle, thus giving perfect access to the parts.

A conveyer may be arranged below the machine, and the material may flow from the base of the case directly to the conveyer, and the falling material may be readily inspected through the openings N, or other suitable off-flow connections may be made at the base of the case within the bed.

The cover and the standing grinder may be moved away, thus leaving the face of the standing grinder and the whole interior of the case accessible for inspection, &c.

The cover may be moved close up to the case, thus bringing the standing grinder into proper working position, and the link-cams H may then be operated to draw the cover up to a close joint with the case, the joint being provided, if desired, with a gasket of yielding material.

The machine may be operated with the parts in this position, or clamp-bar K may be tightened and the links H disengaged, thus causing the cover and running grinder to be held in normal position entirely by the action of the knee-clamp which holds it to the bed. When, however, a foreign substance enters between the grinders, the outward pressure upon the standing grinder, acting after the manner of a lever upon the clamp, will be sufficient to break the clamp, and the cover and standing grinder will then move away from the running grinder and allow the foreign substance to pass without materially destroying the teeth, &c. The case F being split vertically upon the line *b*, the joint being formed by bolts through flanges permits the case to be removed bodily without the necessity for removing the running grinder from the spindle or the spindle from the head-stock.

I claim as my invention—

1. A grinding-mill comprising a rigid horizontal bed, a head-stock thereto, a spindle journaled therein, a running grinder secured to the spindle, a standing grinder arranged to have its face operate in conjunction with the face of the running grinder, and a cover provided with a rigid knee engaging said horizontal bed, and adapted to rigidly support the running grinder in a fixed plane, and adapted for reciprocation along said bed, substantially as and for the purpose set forth.

2. A grinding-mill comprising a rigid horizontal bed, a head-stock rigidly secured thereto, a spindle journaled therein, a running grinder secured to the spindle, a standing grinder, a cover provided with a knee fitted to slide along said bed and to support the standing grinder rigidly in a fixed position, and a case inclosing the grinders and secured to said bed, and having an outlet downwardly through said bed, substantially as and for the purpose set forth.

3. A grinding-mill comprising a rigid horizontal bed, a head-stock secured thereto, a spindle journaled therein, a running grinder

secured to the spindle, a case surrounding the running grinder and having an open front, a cover for the front of said case provided with a rigid knee fitted to slide along said bed and to support said cover rigidly in a fixed plane, and a standing grinder secured upon the inner face of the cover, substantially as and for the purpose set forth.

4. A grinding-mill comprising a rigid horizontal bed, a standing grinder, a cover provided with a rigid knee adapted to slide along said bed and support the standing grinder rigidly in a fixed position, a spindle, a running grinder secured thereto, a head-stock arranged to support said spindle and rigidly secured to said bed, and set-screws, as E, for moving said head-stock sidewise upon the bed, substantially as and for the purpose set forth.

5. A grinding-mill comprising a rigid horizontal bed, a head-stock secured thereto, a running grinder, a spindle journaled in the head-stock and having said running grinder secured to it, and having an end projecting outwardly from the face of the running grinder, a standing grinder, and a cover having a rigid knee and a bearing for said projecting end of the spindle, said knee being fitted to support said standing grinder and spindle and to slide along the bed free of engagement with the spindle, substantially as and for the purpose set forth.

6. A grinding-mill comprising a rigid horizontal bed, a head-stock rigidly secured thereto, a running grinder, a spindle journaled in said head-stock and having said running grinder secured to it, and having an end projecting outward from the front of the running grinder, a standing grinder, and a cover provided with a rigid knee and a bearing for said projecting end of the spindle, said knee being rigidly connected with the standing grinder and fitted to slide along the bed and to support said standing grinder and bearing rigidly in a fixed position, and a step-screw supported by and at the end of said bearing, substantially as and for the purpose set forth.

7. A grinding-mill comprising a bed, a head-stock secured thereto, a spindle journaled therein, a running grinder secured to said spindle, a case surrounding such running grinder and supported by said bed and having a base opening into said bed, doors in the side of the bed at the base of the case, a cover for the front of the case, provided with a knee fitted to slide along the bed, a standing grinder secured to the inner face of the cover, and an inlet-nozzle upon the outer face of the cover communicating axially with the interior of the case, substantially as and for the purpose set forth.

8. A grinding-mill comprising a bed, a head-stock secured thereto, a spindle journaled therein, a running grinder secured to the spindle, a case surrounding the running grinder and having an open front, a cover for the front of said case, provided with a knee fitted to slide along the bed, a standing grinder attached to the inner face of said cover, and a clamp con-

nected with said cover and bed and adapted to hold said cover in normal position against the front of the case, substantially as and for the purpose set forth.

5 9. A grinding-mill comprising a bed, a head-stock secured thereto, a spindle journaled therein, a running grinder secured to the spindle and having an open front, a cover for the front
10 of said case, provided with a knee fitted to slide along on said bed, said cover forming a joint against the front of the case, and cam-links H, pivoted to the case and serving to draw the cover closely thereto, substantially as and for
15 the purpose set forth.

10. A grinding-mill comprising a bed, a head-stock secured thereto, a spindle journaled therein, a running grinder secured to the spindle, a standing grinder supported by said bed
20 and having an inlet-opening through its center, and a feeder-disk disposed at the center of the running grinder and provided with forwardly-hooking curved blades, substantially as shown, and for the purpose set forth.

25 11. In a grinding-mill, the combination of

two disk-like grinders, each having a toothed portion and a surrounding fluted portion, the diameter of the toothed portion of one grinder exceeding the inner diameter of the fluted portions of the other grinder, substantially as and
30 for the purpose set forth.

12. In a grinding-mill, the combination of a grinder having teeth Y, formed with forward cutting-edges, sloping tops, and frontal points, and a grinder formed with teeth Z, having flat
35 fronts, sloping tops, and frontal points, substantially as and for the purpose set forth.

13. In a grinding-mill, the combination, with a grinder having facial teeth and a surrounding series of flutes presenting cutting-edges, of
40 a grinder having facial teeth, a surrounding series of flutes presenting cutting-edges, and an intermediate circle of short flutes presenting forward and rearward slopes, substantially as and for the purpose set forth.

CLAUDIUS G. FREEMAN.

Witnesses:

BEN. V. TYLER,
E. H. SPOONER.